

**Agilis Backlit Panels** combine perforated shapes and dramatic illumination for ceiling & wall designs that make a statement.

**MAIN ASSEMBLY**

Attaches to both traditional 15/16" HD Grid and Maxxit's custom suspension system (shown).

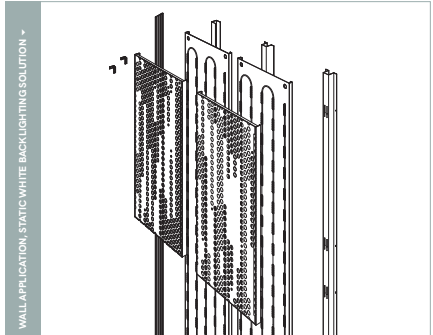
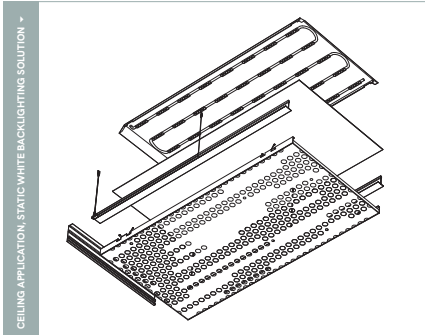
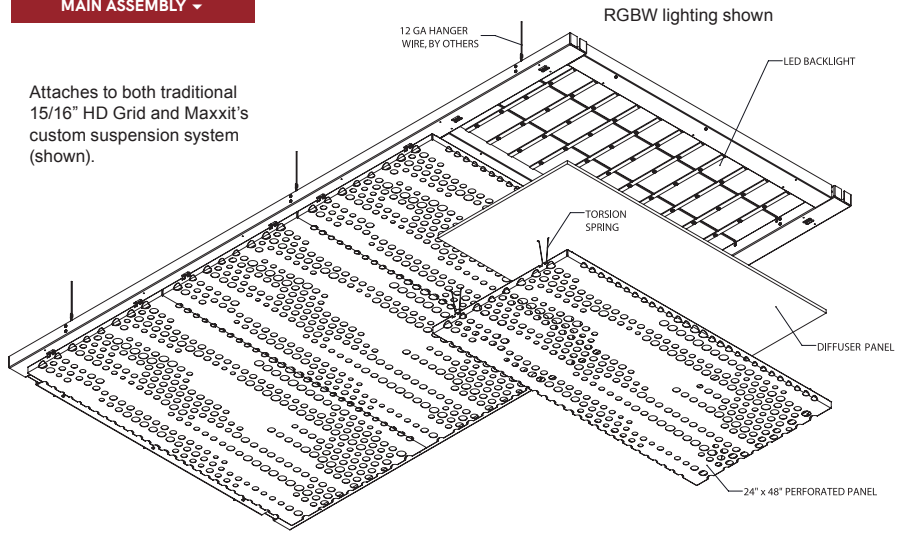

**PHYSICAL DATA**

- Material substrates - Aluminum | Fabricated
- Thickness .041" - .060" design dependent
- Fire Performance - Class A: Tested per ASTM E84. Flame Spread Index 25 or less. Smoke Developed Index 50 or less. CAN/ULC S102 surface burning characteristics. Flame Spread Rating 25 or less. Smoke Developed Classification 50 or less.
- Weight - Varies from 1.0-1.5 lbs./sq.ft.
- Warranty - One Year Limited
- Surface Finish - Factory-applied polyester paint. Available in Standard Colors, Color Matched and Wood Look Powder-Coated and laminated
- Seismic areas - Agilis has been engineered for use in all seismic areas. Installations may require additional attachment from baffle to suspension bar. Check with local code officials or a licensed engineer for additional requirements.

**SUSTAINABILITY**

**CONTRIBUTES TO LEED® POINTS -**

- LEED BD+C: New Construction v4
  - ▶ MR: Regional Materials
  - ▶ MR: Recycled Content
- LEED ID+C: Commercial Interiors v4
  - ▶ EQ: Low-Emitting Material
- No VOC'S: No added urea-formaldehyde
- EPD 'Environmental Product Declaration' for raw material components
- Recycled Content - up to 80%

LEED® is a registered trademark of the U.S. Green Building Council

**FEATURES**

- Create custom perforation patterns for elevated design
- Unlimited finish options - custom colors, wood looks, and films
- Custom sizes & shapes - At Maxxit custom is what we do best. We will make any shape or size you can design.
- Perforations run to the panel edge and are matched to adjacent panels for a more seamless appearance.
- Attaches to both traditional 15/16" HD Grid and Maxxit's custom suspension system (shown).
- Torsion spring design allows for easy access to light panel. Panels can remain hinged to suspension to avoid damage.
- Cleanable using CDC recommended and EPA-approved disinfectants for fog, spray & wipe
- Backlighting options include White and RGBW LED (see Lighting Specification page for details).
- Backlighting should not be relied upon as the primary lighting source. Linear lights can be integrated with backlit panels upon request.

Physical data, Features and Sustainability on this page pertain to the Panels. Refer to the Lighting section for details on lighting.

# PANEL SPECIFICATION

## CEILING APPLICATION

Ceiling panels are designed to be mounted onto standard 15/16" HD Grid using torsion springs.

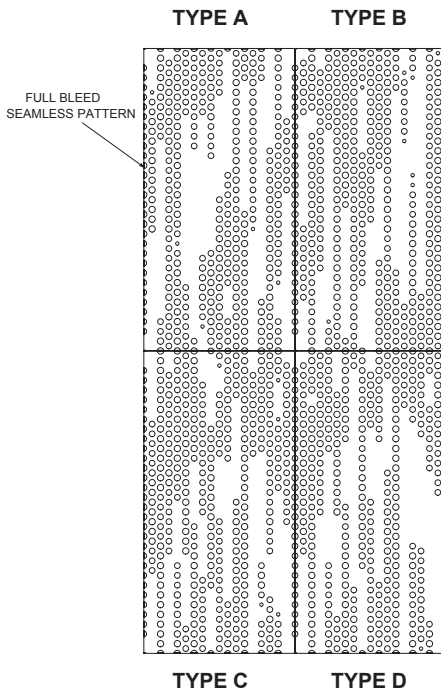
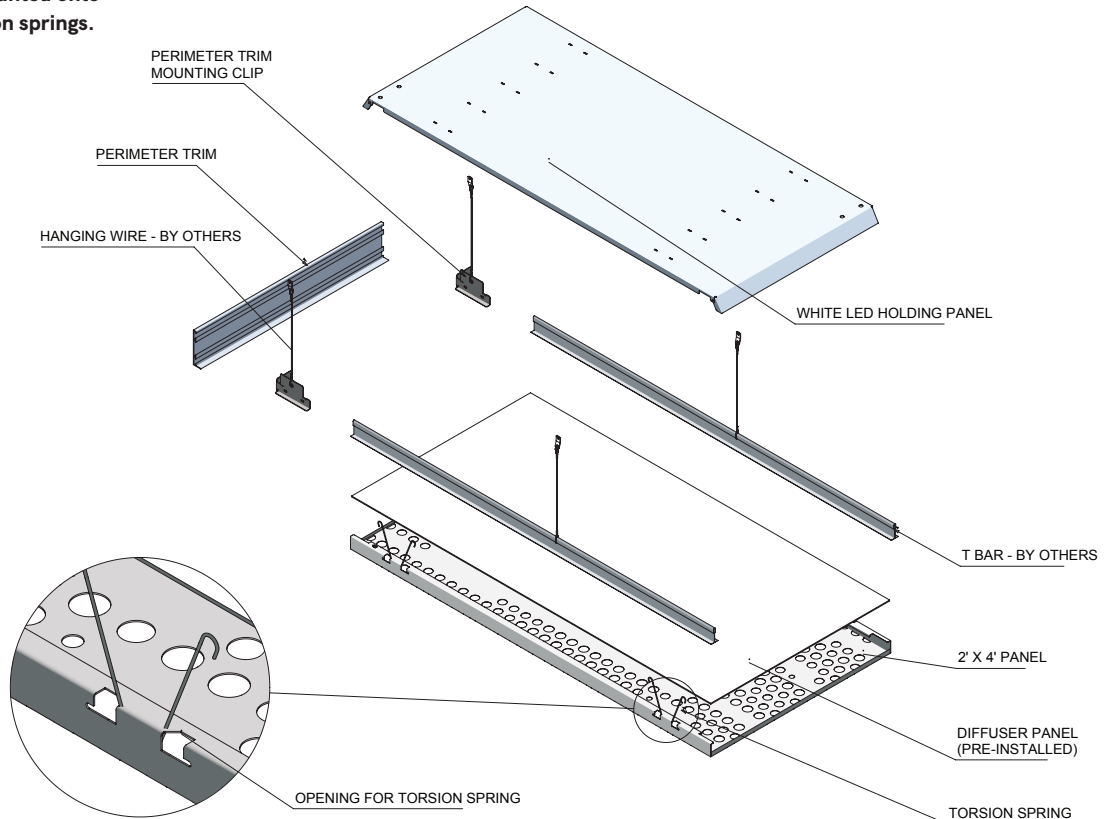

Perforated surface is crafted using four unique tiles arranged strategically to minimize visual repetition, creating a seamless look throughout the space. Ceiling panels have edge-to-edge perforations, subtly blending where each panel joins for a unified look.

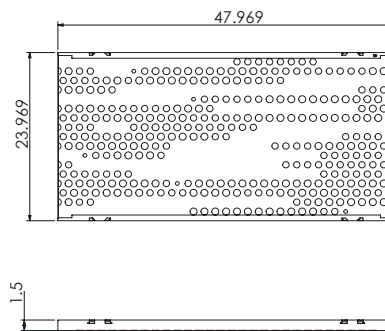

# PANEL SPECIFICATION

## WALL APPLICATION

The wall attachment system includes a series of rails and hooks designed to securely hold the perforated panels in place.

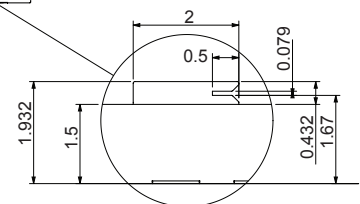
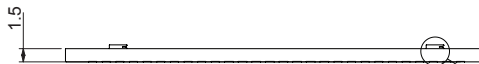
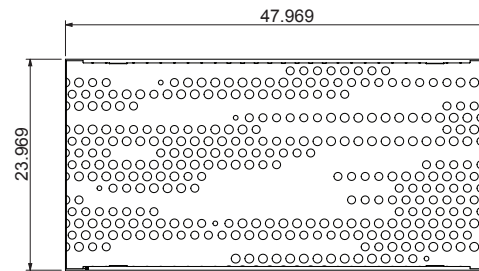
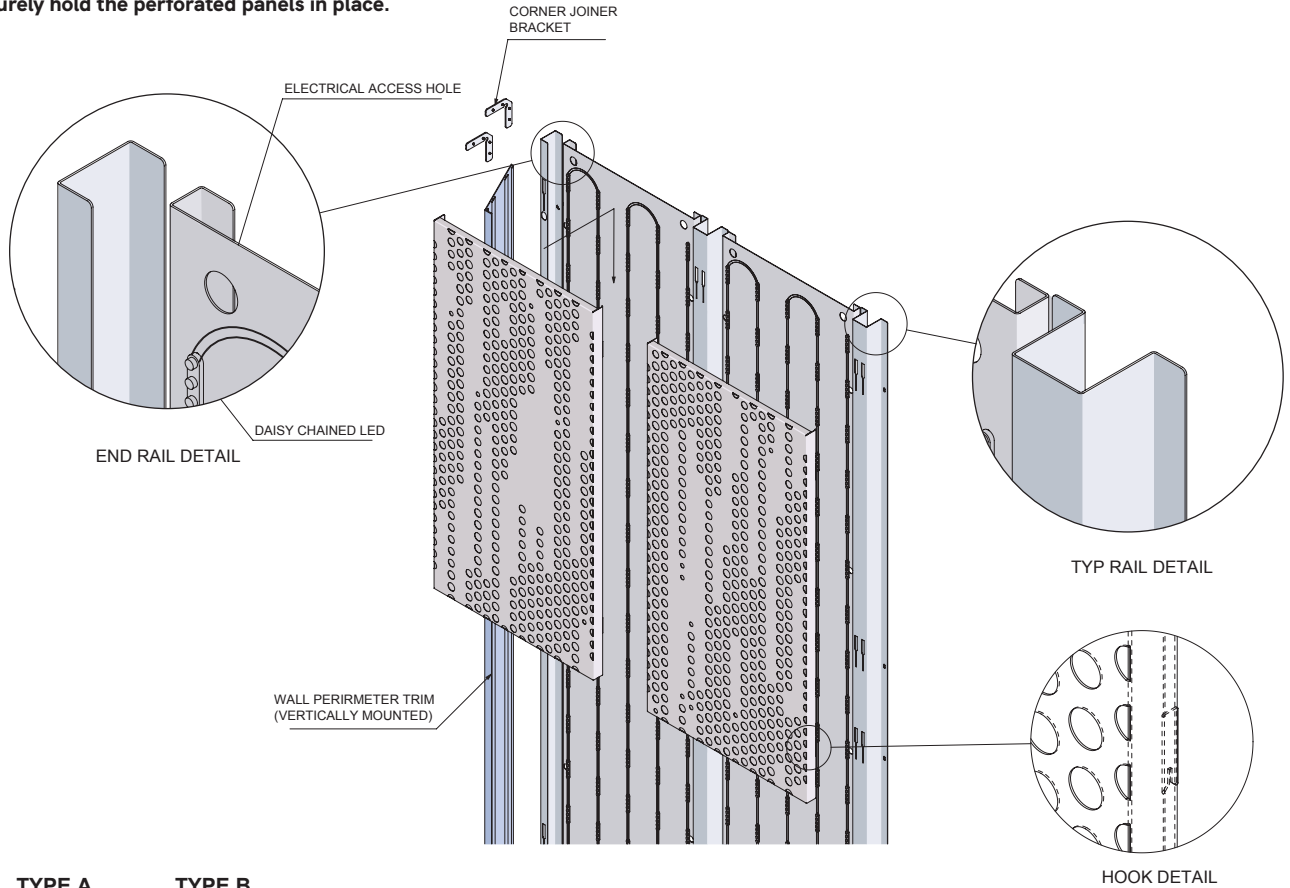

Similar to the ceiling panels, the perforated surface is designed with four distinct tiles arranged for continuous pattern design. Arrange of standard and custom perforation options is available.

# LIGHTING SPECIFICATION

The **Maxxit Agilis back-lit panel system** integrates LED lighting directly into its lightweight, perforated metal ceiling and wall panels, creating a sophisticated, seamless lighting solution. Designed with ease of installation in mind, the Agilis panels feature a modular system that allows for quick assembly and consistent illumination across large spaces. With customizable options for brightness, color temperature, and control systems, Agilis back-lit panels are ideal for commercial environments, offering both functional lighting and a high-end, modern look. Available in White and RGB versions.

## AGILIS BACKLIGHTING SPECIFICATIONS

PHYSICAL DATA	WHITE	RGBW
TOTAL LUMENS	2000-2200 Lm / Panel	1800 Lm / Panel
POWER CONSUMPTION	16 Watts / Panel	72 Watts / Panel
VOLTAGE	24 Volt DC	24 Volt DC
COLOR TEMP	3200K - 7100K	up to 6500 K (White) • Red • Green • Blue
CRI	Up to 84	80+
DIMMING OPTIONS	0-10V dimmable down to 1%; non-dimmable	DMX/RDM 0.1%-100%
EFFICACY	157 Lm / w	Varies depending on color temperature and wattage
BEAM ANGLE	175°	117°
SIZE (L X W X D)	48" x 24" x 2.75" (40 modules/120 LEDs per panel)	48" x 24" x 2.75" (12 bars/108 LEDs per panel)
CERTIFICATIONS	UL Recognized (C-US) #E219167, UL Classified (C-US) #E229508, CE, ROHS • IP66 rated: for dry, damp or wet location	UL Recognized Component, IP20
OPERATING TEMPERATURE	-40°C to +60°C (-40°F to +140°F)	-20°C (-4°F) ~ +60°C (+140°F)
POWER CABLE	Plenum rated, 16AWG	Supplied by installer



# LIGHTING SPECIFICATION

## White Backlighting

- Very low power consumption, making it a sustainable, energy efficient option for all environments
- Wide beam angle produces uniform, consistent light
- Robust and reliable, suitable for both interior and exterior applications
- IES files available
- Easy to install, reposition and cut on site

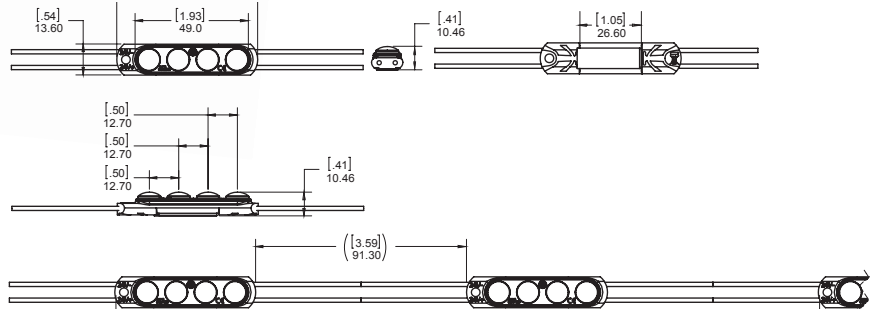
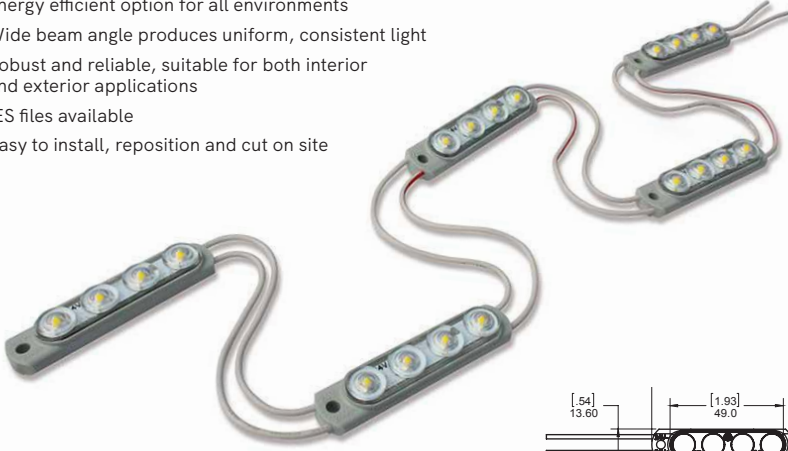

## RGBW Backlighting

- A reliable RGBW 4-in-1 5050 LEDs with high performance
- Forward facing diodes for direct color lux and light uniformity
- Wide range of color options, include white (up to 6500K), red, green and blue
- Indoor use only

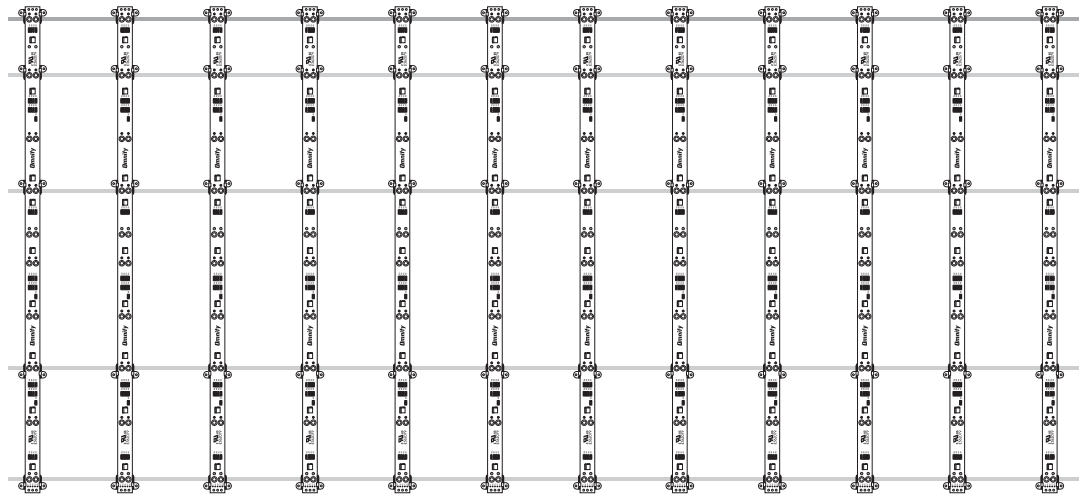

# WOOD LOOK FINISHES

## Standard Powder Coated Paint Finishes (Interior & Exterior) Formaldehyde-Free



## Custom Colors

### FIND YOUR PERFECT MATCH

At Maxxit we have a passion for finishes; wood, metallic, oil rubbed, whatever your challenge is we can match it!

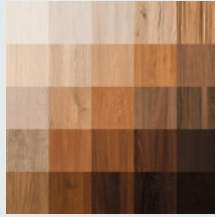

Send us a color sample so we can quickly provide a color match.

## Standard Laminated (Film) Finishes (interior only). Formaldehyde-free



# STANDARD COLORS

Maxxit powder coat finishes offer superior chemical, scratch and UV resistance, they do not emit VOC's and are available in a broad range of textures, glosses and specialty looks.

## Powder Coated Paint Finishes (Interior & Exterior) Formaldehyde-Free



### Custom Colors

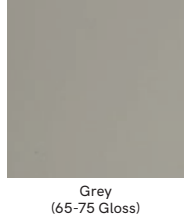
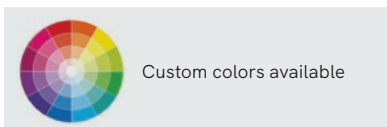

# MADE TO ORDER PATTERNS

**Custom Patterns** Four distinct design families, each with customizable parameters. Whether it's adjusting hole diameter, pattern density, or scale, we can create virtually endless variations of each pattern to suit individual needs and preferences. **Create your perfect design:**

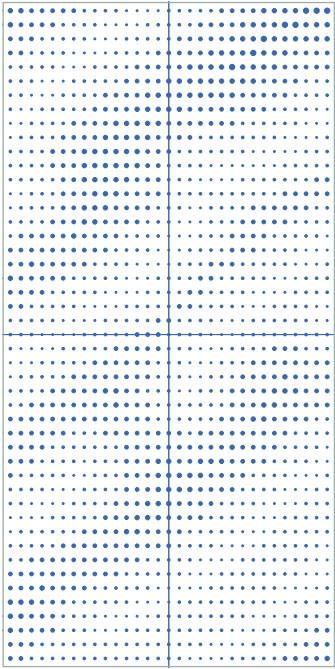

Aqua Flow

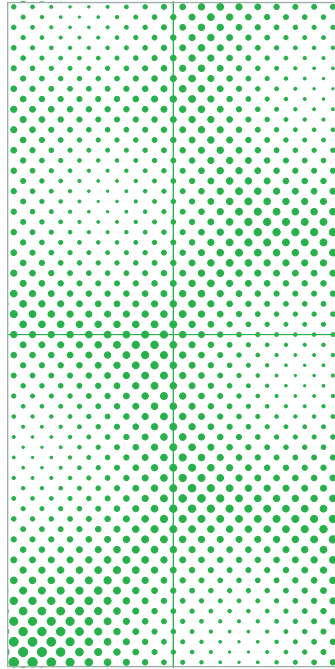

Radial Glow

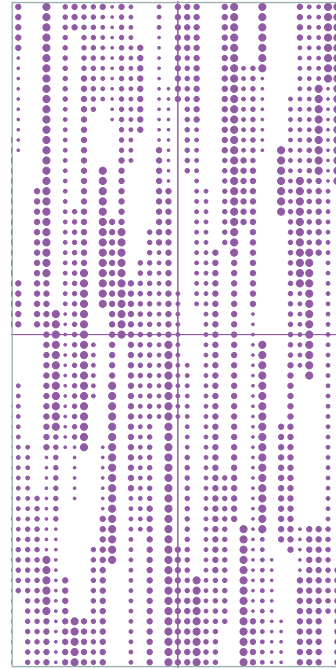

Bitstream

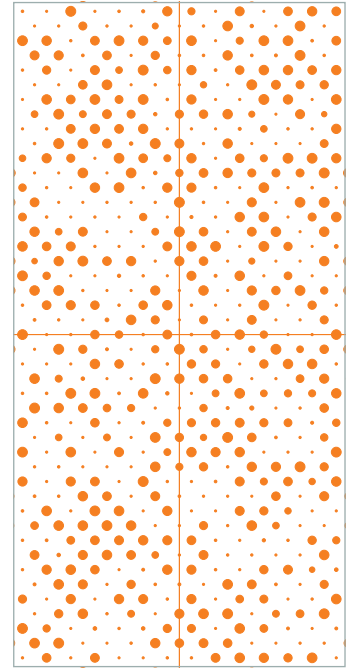

Starlight

**Perforated Imaging** Perforated imaging employs high-tech manufacturing methods to create detailed images using perforations. Supply us an image, logo or text and we'll apply it onto a metal panel, providing your space with a customized design.





# AGILIS DESIGNS

CUSTOM NETWORKS ▾

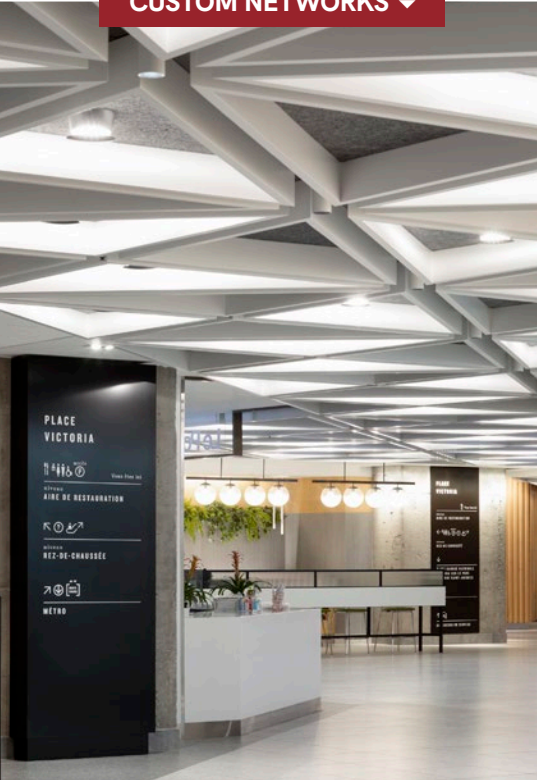

SHUFFLE ▾



NETWORKS ▾



BACKLIT ▲



PANELS ▲



WIRE MESH ▲





# DESIGN REALIZED

From the familiar to the truly one of a kind, Maxxit brings your design vision to life. With ceilings and walls crafted from Wood, Felt, Metal, Composites & more there is no limit to what we can create together.

